



1600

Quick Start Guide

Environment conditions

Environment	Operating	Non-Operating
Ambient temperature	5°C (41°F) to 40°C (104°F)	-20°C (-4°F) to 60°C (140°F)
Humidity	10% RH to 80% RH Non-condensed	10% RH to 90% RH Non-Condensed
Altitude	0 m (0 Ft) to 2500 m (8202 Ft)	-60 m (-197 Ft) to 10000 m (32810 Ft)
Air cleanness	Clean office environment ¹	n.a.



WARNING: Ensure that the physical environment in which the projector is installed, complies at all times with the environmental requirements summarized in this chapter! Never use the projector in case not all requirements are fulfilled. Neglecting will damage the projector and will void the warranty.

Remote control & local keypad

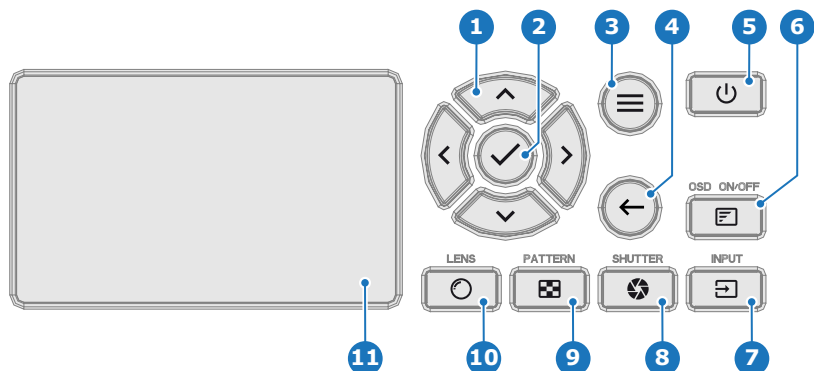
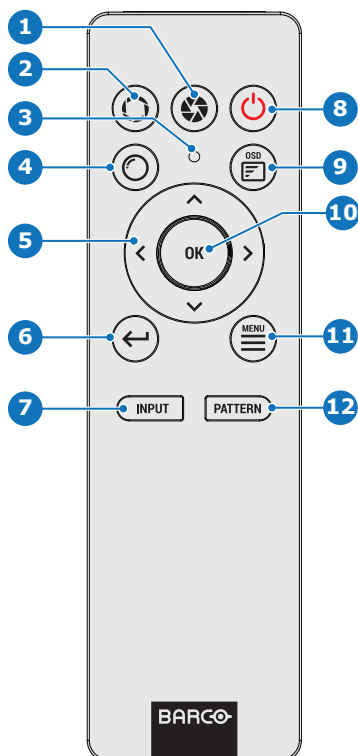

- 1 Shutter close
- 2 Shutter open
- 3 Button pressed
- 4 Lens menu
- 5 Navigation
- 6 Menu back
- 7 Input selection
- 8 Power On/Off
- 9 OSD On/Off
- 10 Confirmation
- 11 Menu enter/exit
- 12 Test patterns

- 1 Navigation
- 2 Confirmation
- 3 Menu enter/exit
- 4 Menu back
- 5 Power On/Off
- 6 OSD On/Off

- 7 Input selection
- 8 Shutter open/close
- 9 Test patterns
- 10 Lens menu
- 11 LCD touch panel

1. Equivalent with cleanroom standard ISO 14644-1 ISO Class 9.



Main Power requirements



- The projector operates from a nominal mono phase power net with a separate earth ground PE.
- Power requirements : 100V-240V (+/-10%), 15A-6A, 50-60Hz.
- The projector must be grounded.
- The power cord delivered with the projector must be used.











CAUTION: It is important to read the installation instructions before connecting the equipment to the mains power supply.

Button backlight status

The Power and Shutter buttons are equipped with white, blue and red backlit LEDs. The other keys are only equipped with white and blue backlit LEDs. The LEDs are controlled according to the features available.

Button	Color status	Description
	Short WHITE pulse	Projector starts up (booting), or is in ECO STANDBY
	Blinking WHITE	Firmware update, or in transition from ECO STANDBY to STANDBY
	Solid WHITE	Projector is in STANDBY or READY mode
	Blinking BLUE	Projector goes to ON mode
	Solid BLUE	Projector is ON
	Blinking RED	Error condition
	Off (no color)	Projector is OFF, starts up, or is in STANDBY or READY mode
	Solid WHITE	Projector is ON, shutter is open
	Solid RED	Projector is ON, shutter is closed

ILD lenses

Order No	Name (Screening) / Comments	Image	Resolution	Throw Range
R9803077	ILD lens 0.37 : 1 (requires lens support)		4K UHD 0.8"	(0.37 : 1)
R9803076	ILD lens 0.5 : 1 (requires lens support)		4K UHD 0.8"	(0.5 : 1)
R9803072	ILD lens 0.65 - 0.8 : 1		4K UHD 0.8"	(0.65 - 0.8 : 1)
R9803071	ILD lens 0.8 - 1.0 : 1		4K UHD 0.8"	(0.8 - 1.0 : 1)
R9803070	ILD lens 1.0 - 1.4 : 1		4K UHD 0.8"	(1.0 - 1.4 : 1)
R9803061	ILD lens 1.4 - 2.1 : 1		4K UHD 0.8"	(1.4 - 2.1 : 1)
R9803075	ILD lens 2.1 - 4.0 : 1		4K UHD 0.8"	(2.1 - 4.0 : 1)
R9803073	ILD lens 4.0 - 7.4 : 1		4K UHD 0.8"	(4.0 - 7.4 : 1)

Install the projection lens

1. Gently insert the lens in the lens holder while aligning the **short red line** on the lens body with the red line on the projector top cover (reference 1,).
2. Once the lens is completely inserted, rotate the lens body clockwise until the **long red line** on the lens body is aligned with the red line on the projector top cover.

A click indicates that the lens mount mechanism is locked.

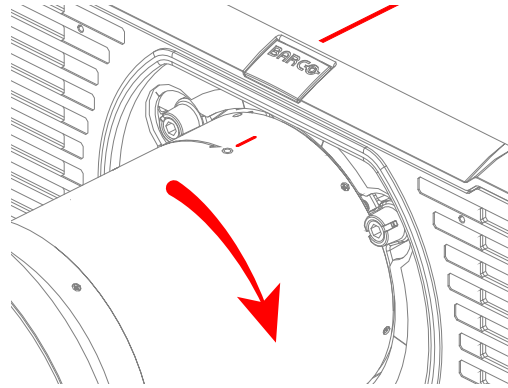
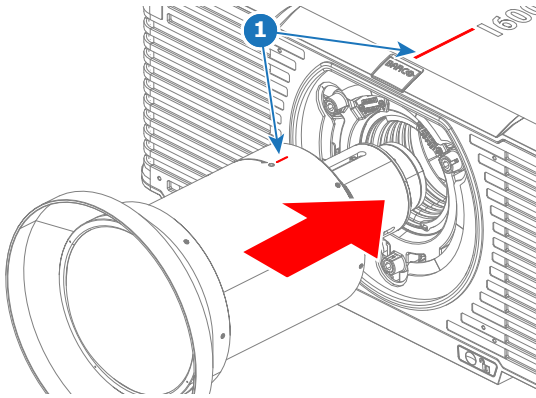

3. Check if the lens is securely locked by trying to rotate the lens body counter clockwise. This should not be possible!

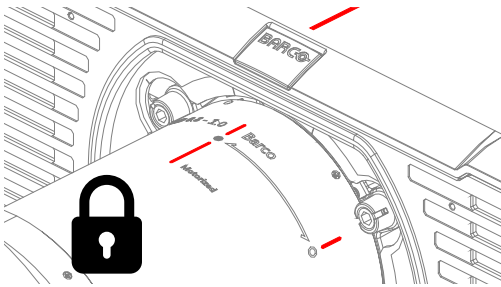

Power up the projector

1. Connect the mains power cord to the power inlet connector.
2. The projector will perform the startup sequence. When ready, the power button on the keyboard will illuminate white, meaning that the projector is in ready mode.
3. Press the Power button on the keypad or remote. The power button will after some seconds illuminate solid blue, meaning that the projector is ON.

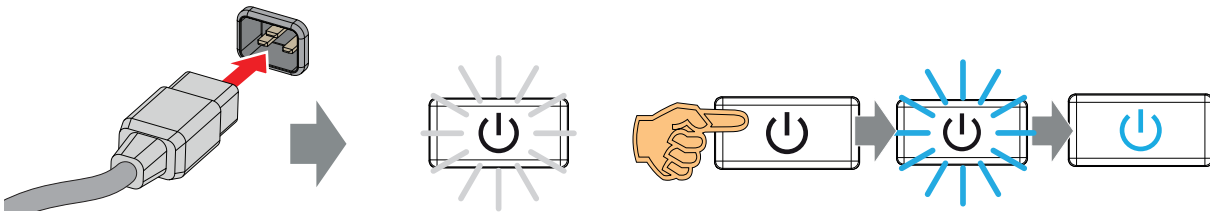

Connecting with Pulse Prospector

1. Start a web browser.
2. Enter the projector's IP address (xxx.xxx.xxx.xxx).

 *Note:* In order to connect a device (e.g., laptop) with the projector, both the device and the projector must operate within the same network (or the device needs to have full access to the projector network).

 *Tip:* The projector IP address is visible on the projector touch screen when the dashboard of the Pulse OSD is displayed.

Front panel Control & Communication module

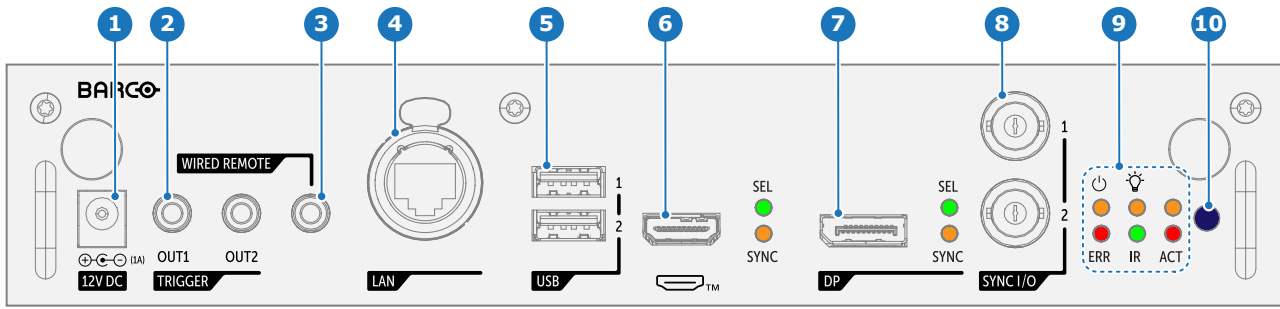

- | | | | |
|---|--------------|----|-----------------------|
| 1 | 12V DC | 6 | HDMI™ |
| 2 | TRIGGER | 7 | DP |
| 3 | WIRED REMOTE | 8 | SYNC I/O |
| 4 | LAN | 9 | Projector status LEDs |
| 5 | USB | 10 | IR receiver |

Front panel Quad Combo Input Mk II

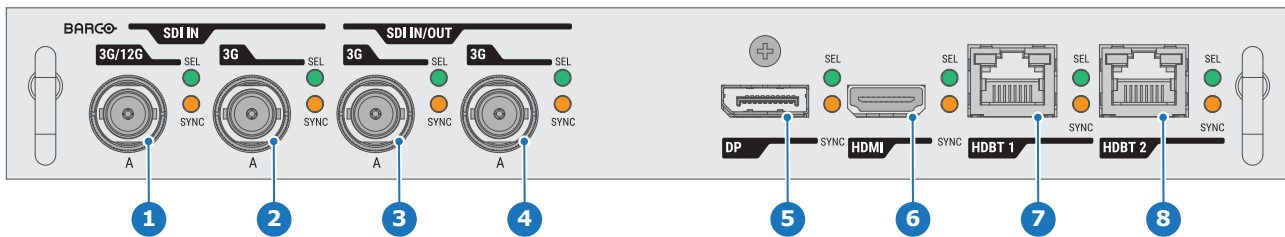

- | | | | |
|---|--|---|-------------------|
| 1 | Quad SDI channel A: 3G/12G input | 5 | DisplayPort Input |
| 2 | Quad SDI channel B: 3G input | 6 | HDMI™ input |
| 3 | Quad SDI channel C: 3G SDI input + 3G/12G output | 7 | HDBaseT input 1 |
| 4 | Quad SDI channel D: 3G SDI input / output | 8 | HDBaseT input 2 |

Front panel Quad Combo Input Mk III

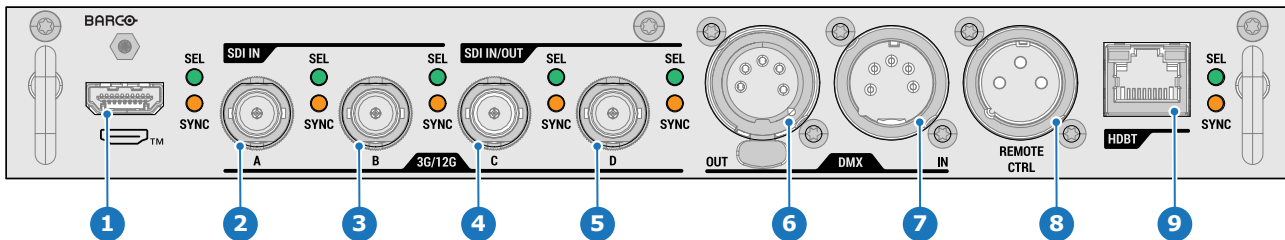

- | | | | |
|---|---|---|---------------------------------|
| 1 | HDMI™ input? | 6 | DMX interface input |
| 2 | Quad SDI channel A: 3G/12G input | 7 | DMX interface output |
| 3 | Quad SDI channel B: 3G/12G input | 8 | XLR for wired projector control |
| 4 | Quad SDI channel C: 3G/12G input/output | 9 | HDBaseT input |
| 5 | Quad SDI channel D: 3G/12G input/output | | |

Front panel Quad DP 1.2 input

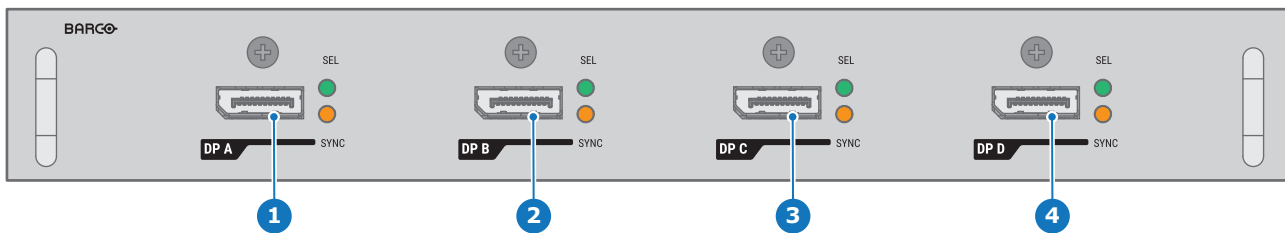

- | | |
|---|----------------------------------|
| 1 | Quad DisplayPort channel A input |
| 2 | Quad DisplayPort channel B input |
| 3 | Quad DisplayPort channel C input |
| 4 | Quad DisplayPort channel D input |

2. The terms HDMI, HDMI High-Definition Multimedia Interface, HDMI trade dress and the HDMI Logos are trademarks or registered trademarks of HDMI Licensing Administrator, Inc.

Front panel Pulse HDBaseT input



Connect and select source

1. **Connect** available sources to the appropriate input ports.
2. **Select** connected source. (See Pulse OSD user guide for detailed menu navigation steps).
 - **Select** LED (reference 1)
 - GREEN : port configured as input. Image appears on the screen.
 - Blinking GREEN : bidirectional port configured as output/loopthrough.
 - **Sync** LED (reference 2)
 - YELLOW : sync/signal is present.

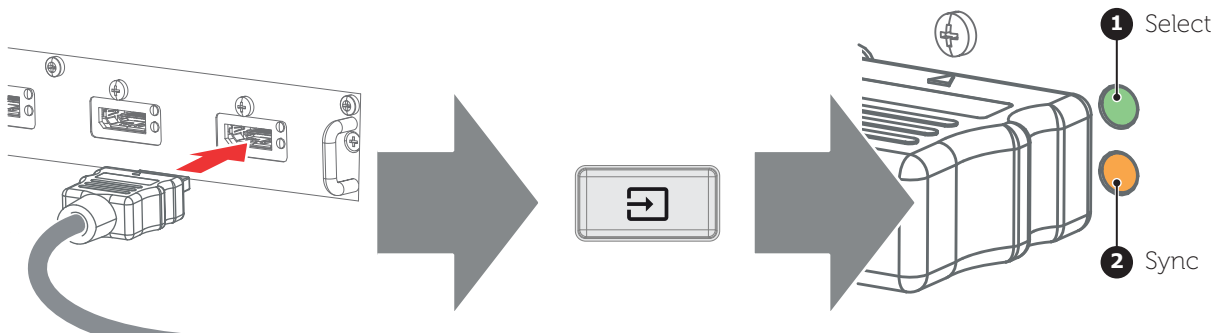

Adjust

1. **Adjust the lens settings** by pressing the lens menu button on the keypad or via the zoom, shift and focus buttons on the keypad.



2. **Orientation** of the unit is set as standard in table front projection mode.
Change the projector set up in the *Installation > Position > Orientation* menu.
3. For **Advanced adjustments** like Warping, Light management, etc. see Pulse OSD user guide.

Power down the projector

1. Press and hold the power button for 3 seconds. (A timer indicator will show up on the display).
2. The power button illumination will become white, and projector will enter the cool down mode for approximately 5 minutes.
3. When the backlight for the keypad is off, unplug the power cord from the projector.

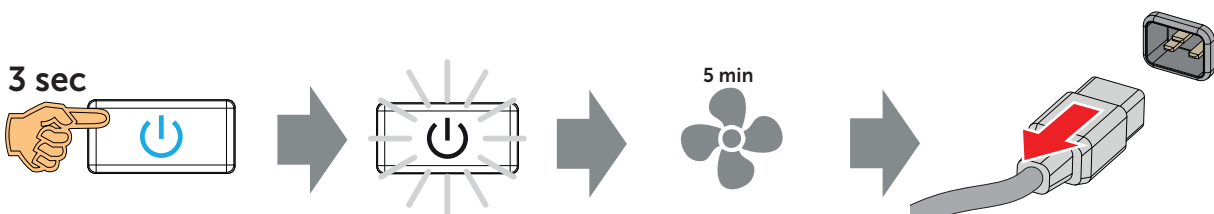

Remove the projection lens

1. Support the lens with one hand.
2. Push the lens unlock button with the other hand while rotating the lens a few degrees counter clock wise. The lens unlock button is located bottom right of the lens holder.
3. Hold the lens with both hands and rotate it further counter clockwise until the **short red line** on the lens body is aligned with the red line on the projector top cover (reference 1).

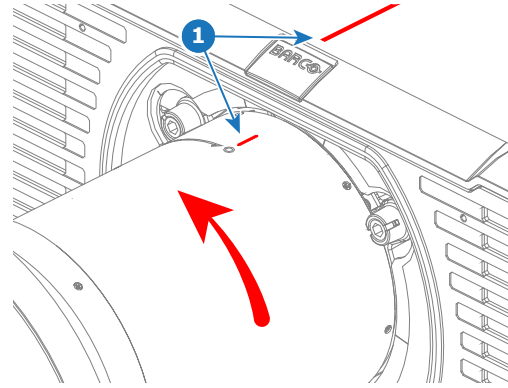
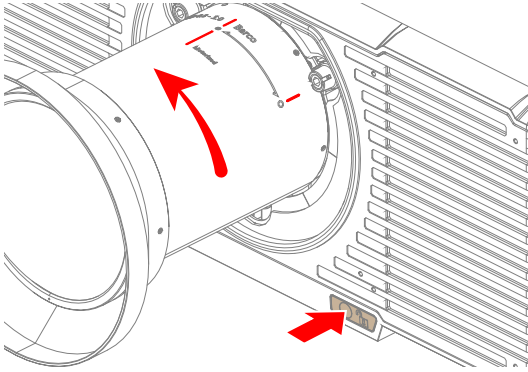

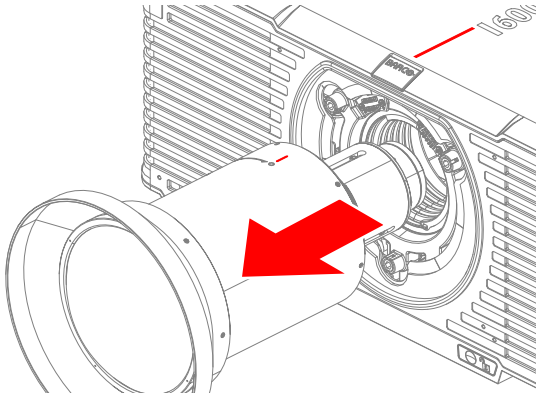

4. Pull the lens straight out of the lens holder.

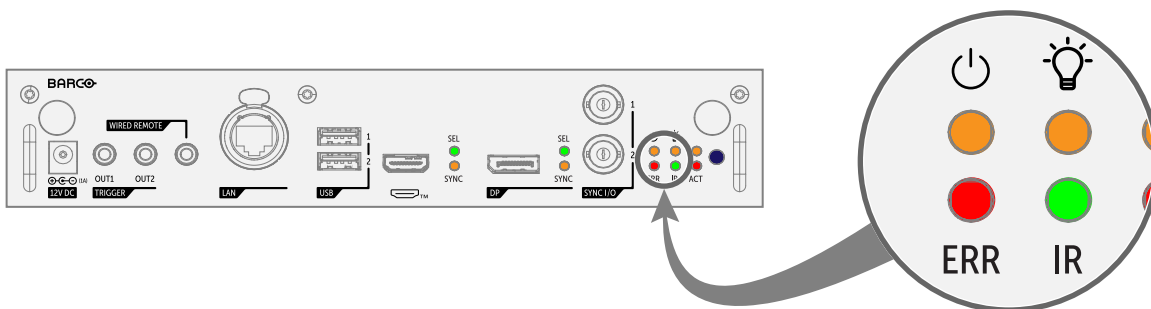

Projector status indicator LEDs

The Control & Communication module contains four status LEDs at the right side of the front panel. These LEDs allows a quick status analyses of the projector. For explanatory see table hereunder.



LED	Color status	Description
 Power	Off	Projector is in ECO STANDBY mode, or is powering up
	RED	Projector is in STANDBY mode
	ORANGE	Projector is in READY mode
	GREEN	Projector is ON
 Illumination	Off	Light source is OFF
	RED	No light source detected
	ORANGE	Light source is on in ECO mode

LED	Color status	Description
	GREEN	Light source is on in normal mode
	GREEN-ORANGE	Light source is on in CLO mode
ERR	Off	No error
	RED toggles on/off	Error
	ORANGE toggles on/off	Warning
IR	RED	IR signal received
	GREEN	IR signal acknowledged

Power transition diagram

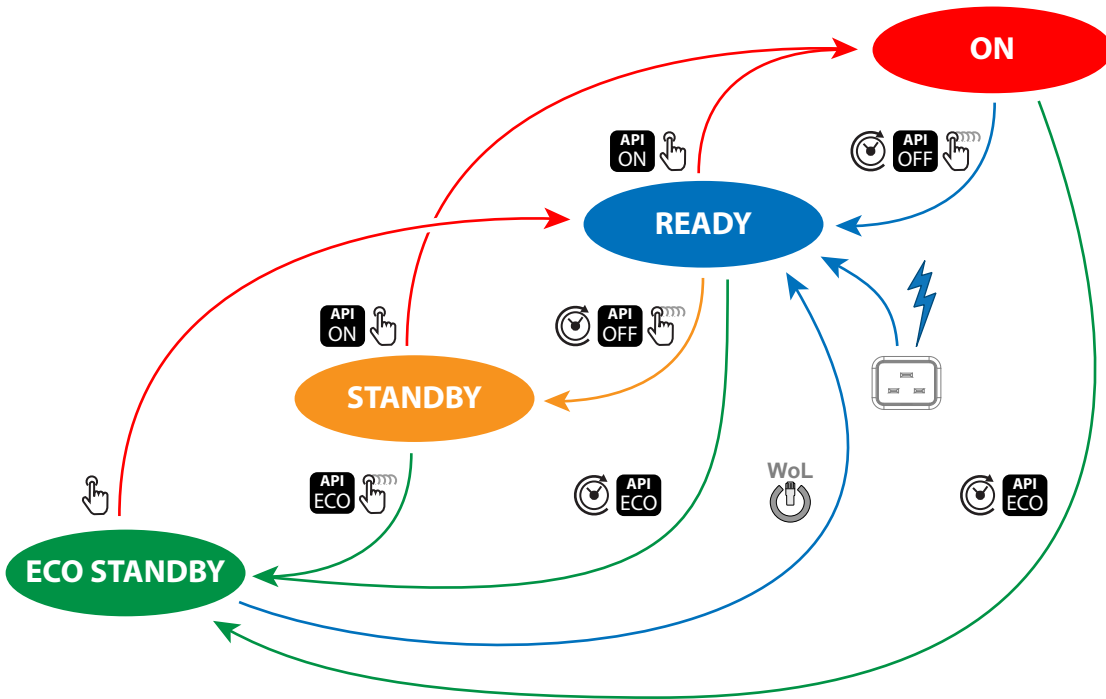

Symbol	Description
	Short pressing the Power on/off button on the local keypad or on the remote control unit.
	Long pressing the Power on/off button on the local keypad or on the remote control unit.
	Wake-On-LAN (WOL). Only works if a network was connected with the LAN port of the projector while the projector went to ECO STANDBY .
	API command to change the power state of the projector (Power ON, Power OFF, Go to ECO). See Pulse user guide for more info (E.g. PJLink).
	Auto light source off and auto standby features. Default disabled (factory settings). For configuration see power saving settings in the Pulse user guide.
	The projector starts default up in READY mode when it is powered.

Pulse Remote Control Unit

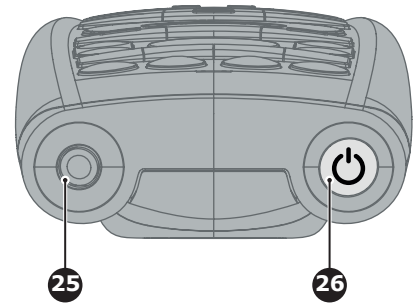
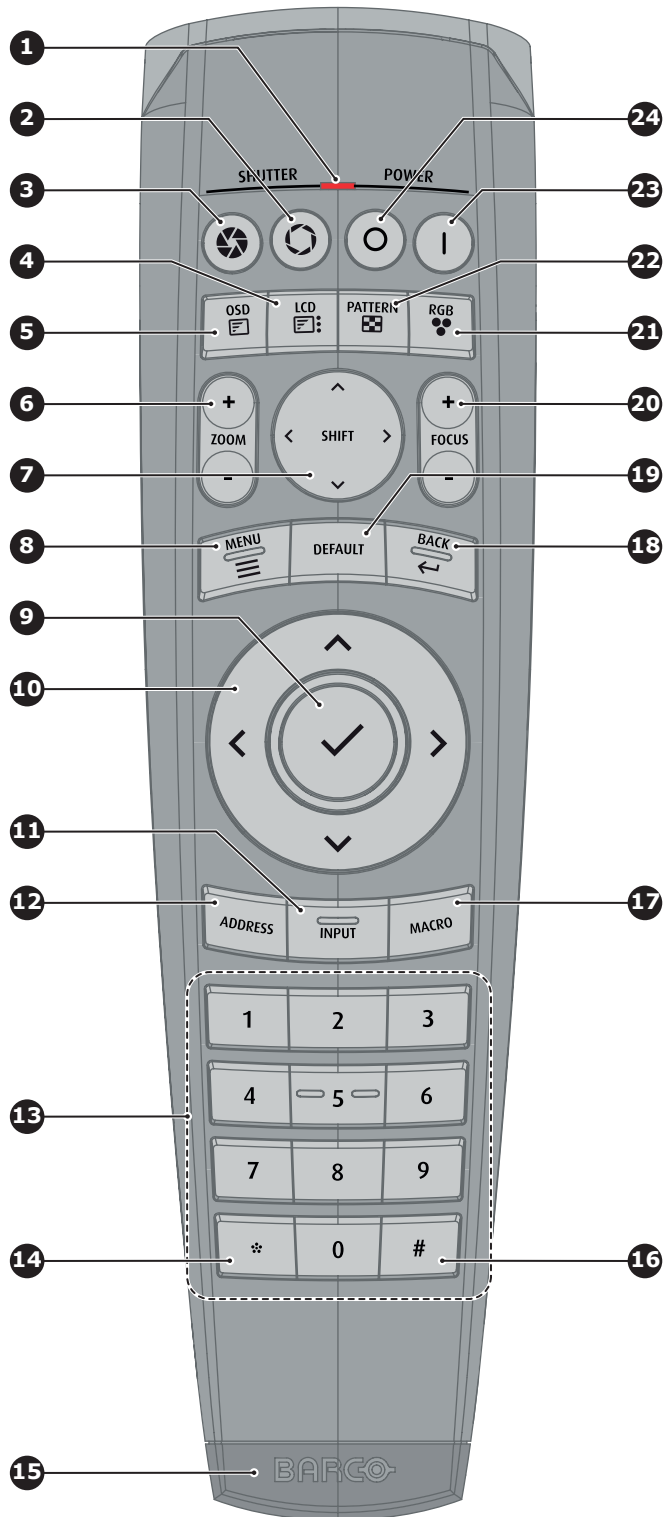

- 1 Button pressed indicator
- 2 Shutter open
- 3 Shutter close
- 4 LCD panel on / off
- 5 Project OSD on / off
- 6 Lens zoom
- 7 Lens shift
- 8 Menu open / close
- 9 Menu selection, OK button
- 10 Menu navigation
- 11 Input selection
- 12 Address button
- 13 Numeric buttons
- 14 Backspace (while entering values)
- 15 XLR connector
- 16 Decimal mark (while entering values)
- 17 Macro button
- 18 Menu back
- 19 Default value button
- 20 Lens focus
- 21 RGB filter
- 22 Test patterns
- 23 Power on
- 24 Power off
- 25 3.5 mm jack
- 26 RCU on / off



CAUTION: Replace batteries with the correct battery type. Use AAA size batteries for the basic RCU and AA size batteries for the Pulse RCU. There is a risk of explosion if the battery is replaced with an incorrect type. Use alkaline batteries for optimum range and life time. Make sure the polarities match the + and - marks, as depicted on the inside of the battery compartment. There is a risk of explosion if the batteries are installed incorrectly.



Replacing batteries will reset the broadcast address of the Pulse RCU to its default value '0'. Replacing batteries of the Pulse RCU switches on the Pulse RCU automatically.



In order to make sure you can control your projector remotely, Barco has provided a basic remote control unit in case the Pulse RCU is not available to you. While the basic remote control has a more limited amount of available features, it will be able to help you out with basic controls.