

Lamp Module Replacement Instructions: SP-LAMP-078

NOTES:

Always use the InFocus lamp module designed for your projector model. Using the wrong lamp module may cause premature lamp failure and possible damage to the projector.

You can order new lamps from www.infocus.com (in select areas), your retailer or your dealer. **Only genuine InFocus lamps are tested for use in this projector.** Use of non InFocus lamps may cause electrical shock and fire, and may void the projector warranty. InFocus is not liable for the performance, safety or certification of any other lamps.

WARNINGS:

- The projector uses a high-pressure mercury glass lamp. The lamp may fail prematurely, or it may rupture with a popping sound if jolted, scratched, or handled while hot. The risk of lamp failure or rupture also increases as the lamp age increases; please replace the lamp when you see the "Replace Lamp" message.
- To avoid burns, allow the projector to cool for at least 60 minutes before you replace the lamp.
- Unplug the power cord before replacing the lamp.
- Do not drop the lamp module. The glass may shatter and cause injury.
- Do not touch the glass surface of the lamp module. Fingerprints can obscure projection sharpness and may cause the glass to shatter.
- Be extremely careful when removing the lamp module. In the unlikely event that the lamp ruptures, small glass fragments may be generated. The lamp module is designed to contain most of these fragments, but use caution when removing it.
- Before replacing a ruptured lamp, clean the lamp compartment and dispose of cleaning materials. Wash hands after lamp replacement.
- When replacing the lamp while the projector is ceiling-mounted, wear protective eyewear to prevent eye injury.
- Hg-Lamp contains mercury. Manage with accordance with local disposal laws. See www.lamprecycle.org

1. Turn off the projector and unplug the power cord.
2. Wait 60 minutes to allow the projector and lamp to cool thoroughly.
3. Remove the lamp door, located on top of the projector, by removing the screws on either side of the lamp door, sliding the door forward and lifting it off.
4. Loosen the captive screws that attach the lamp housing to the projector.

NOTE: If the projector is installed on a ceiling mount, be careful not to drop the lamp module once the captive screws are loosened.

5. Carefully lift the lamp straight up, off of the alignment pins; being careful not to pinch the lamp connector. **Dispose of the lamp in an environmentally proper manner.**
6. Install the new lamp module, aligning the pins properly. Be careful not to pinch the lamp connector.
7. Tighten the screws. (NOTE: If the pins have not been aligned properly, the screws will not tighten securely.)
8. Replace the lamp door by (a) aligning the door, (b) sliding it towards the back and (c) locking it back into place.
9. Replace the lamp door screws and tighten securely.
10. Plug in the power cord and press the **Power** button to turn the projector back on.
11. To reset the lamp hour timer, navigate to the **Advanced Menu > Status/Service** menu and select **Reset Lamp Hours**.

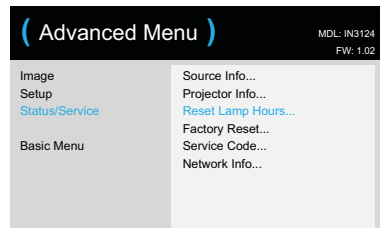
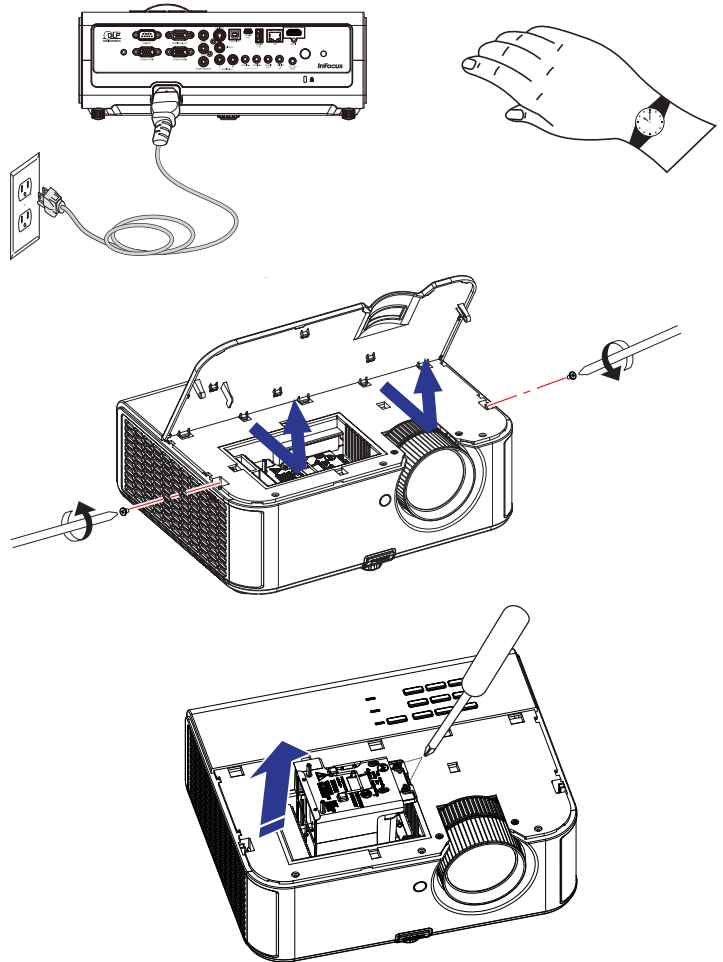

PL939-4800-00

